



SPT-P1303-20(D)

155Mbps SFP Optical Transceiver, 20km Reach

Features

- Up to 155Mbps data-rate
- 1310nm FP laser and PIN photo detector for 20km transmission
- Compliant with SFP MSA and SFF-8472 with duplex LC receptacle
- Digital Diagnostic Monitoring: Internal Calibration or External Calibration
- Compatible with RoHS
- +3.3V single power supply
- Compatible with the patch cords ITU G.652D, G.657A and G.657B (in the impact part) and the core/cladding of bidirectional transmission on single-mode optical fiber is 9/125 μm^2 , "Hot plug" with LC type optical interface connector.
- Comply with 1000Base BX20 based on IEEE802.3ah standard, and the allowable range is up to 20km.
- The SFP have automatic gain control so that it can be installed within 5 meters of the maximum range (the maximum attenuation supported according to the sensitivity of the receiver) without using an attenuator.
- Comply with digital diagnosis monitoring interface.
- Comply with CE and FCC certification.
- Operating case temperature:
 - Standard: 0 to +70°C
 - Industrial: -40 to +85°C

Applications

- SDH STM-1, S-1.1
- SONET OC-3 IR1
- Other optical links

Description



The SFP transceivers are high performance, cost effective modules supporting 155Mbps data-rate and 20km transmission distance with SMF. The transceiver consists of three sections: a FP laser transmitter, a PIN photodiode integrated with a trans-impedance preamplifier (TIA) and MCU control unit. All modules satisfy class I laser safety requirements. The transceivers are compatible with SFP Multi-Source Agreement (MSA) and SFF-8472. For further information, please refer to SFP MSA.

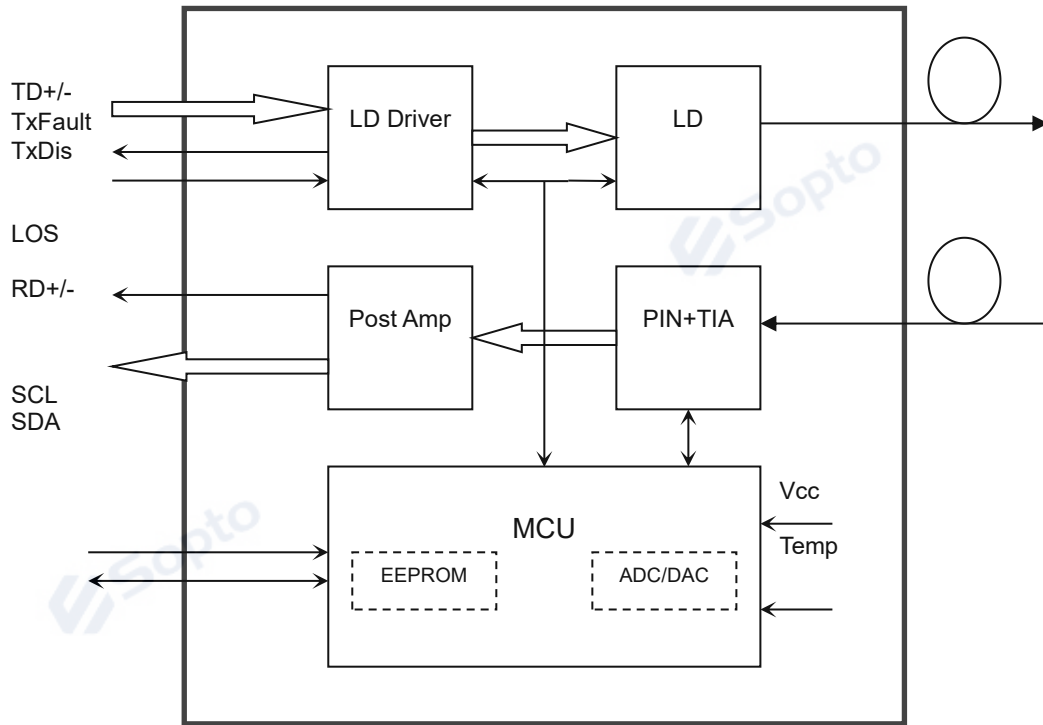

Absolute Maximum Ratings

Parameter	Symbol	Min	Max	Unit
Supply Voltage	Vcc	-0.5	4.5	V
Storage Temperature	Ts	-40	+85	°C
Operating Humidity	-	5	85	%

Recommended Operating Conditions

Parameter	Symbol	Min	Typical	Max	Unit
-----------	--------	-----	---------	-----	------



Operating Case Temperature	Standard	Tc	0		+70	°C
	Industrial		-40		+85	°C
Power Supply Voltage		Vcc	3.13	3.3	3.47	V
Power Supply Current		Icc			160	mA
Data Rate				155		Mbps

Optical and Electrical Characteristics

SPT-P1303-20(D): (FP and PIN, 1310nm, 20km Reach)

Parameter	Symbol	Min	Typical	Max	Unit	Notes
Transmitter						
Centre Wavelength	λ_c	1260	1310	1360	nm	
Spectral Width (RMS)	$\Delta\lambda$			4	nm	
Average Output Power	Pout	-15		-7	dBm	1
Extinction Ratio	ER	8			dB	
Data Input Swing Differential	VIN	400		1800	mV	2
Input Differential Impedance	ZIN	90	100	110	Ω	
TX Disable	Disable	2.0		Vcc	V	
	Enable	0		0.8	V	
TX Fault	Fault	2.0		Vcc	V	
	Normal	0		0.8	V	
Receiver						
Centre Wavelength	λ_c	1260		1580	nm	
Receiver Sensitivity				-34	dBm	3
Receiver Overload		-3			dBm	3
LOS De-Assert	LOSD			-35	dBm	
LOS Assert	LOSA	-46			dBm	
LOS Hysteresis		1		4	dB	
Data Output Swing Differential	Vout	370		1800	mV	4
LOS	High	2.0		Vcc	V	
	Low			0.8	V	

Notes:

1. The optical power is launched into SMF.
2. PECL input, internally AC-coupled and terminated.
3. Measured with a PRBS 2²³-1 test pattern @155Mbps, BER $\leq 1 \times 10^{-10}$
4. Internally AC-coupled.



Timing and Electrical

Parameter	Symbol	Min	Typical	Max	Unit
Tx Disable Negate Time	t_on			1	ms
Tx Disable Assert Time	t_off			10	μs
Time To Initialize, including Reset of Tx Fault	t_init			300	ms
Tx Fault Assert Time	t_fault			100	μs
Tx Disable To Reset	t_reset	10			μs
LOS Assert Time	t_loss_on			100	μs
LOS De-assert Time	t_loss_off			100	μs
Serial ID Clock Rate	f_serial_clock			400	KHz
MOD_DEF (0:2)-High	VH	2		V _{cc}	V
MOD_DEF (0:2)-Low	VL			0.8	V

Diagnostics

Parameter	Range	Unit	Accuracy	Calibration
Temperature	0 to +70	°C	±3°C	Internal / External
	-40 to +85			
Voltage	3.0 to 3.6	V	±3%	Internal / External
Bias Current	0 to 100	mA	±10%	Internal / External
TX Power	-15 to -7	dBm	±3dB	Internal / External
RX Power	-34 to -3	dBm	±3dB	Internal / External

Digital Diagnostic Memory Map

The transceivers provide serial ID memory contents and diagnostic information about the present operating conditions by the 2-wire serial interface (SCL, SDA). The diagnostic information with internal calibration or external calibration all are implemented, including received power monitoring, transmitted power monitoring, bias current monitoring, supply voltage monitoring and temperature monitoring. The digital diagnostic memory map specific data field defines as following.

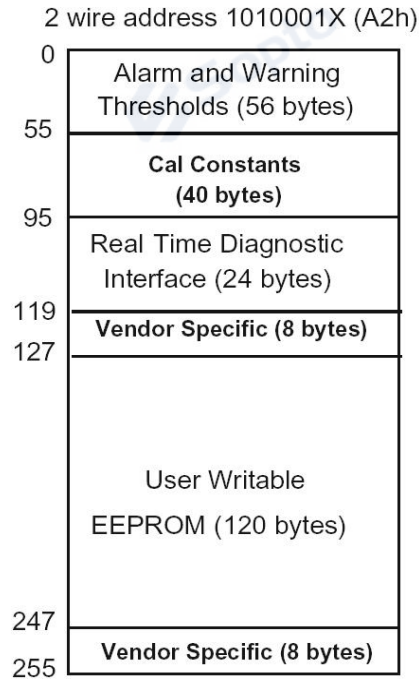
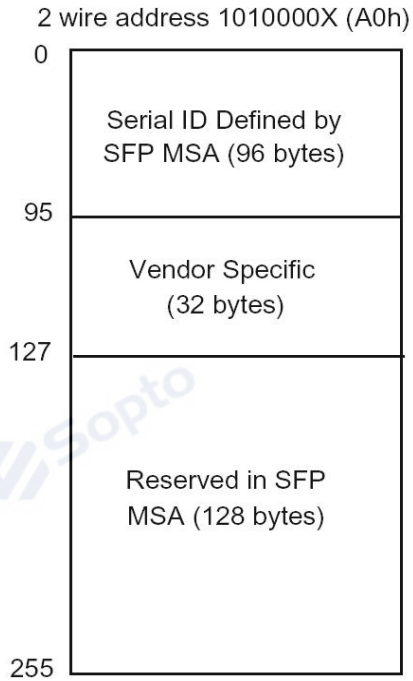

Pin Definitions

Pin Diagram

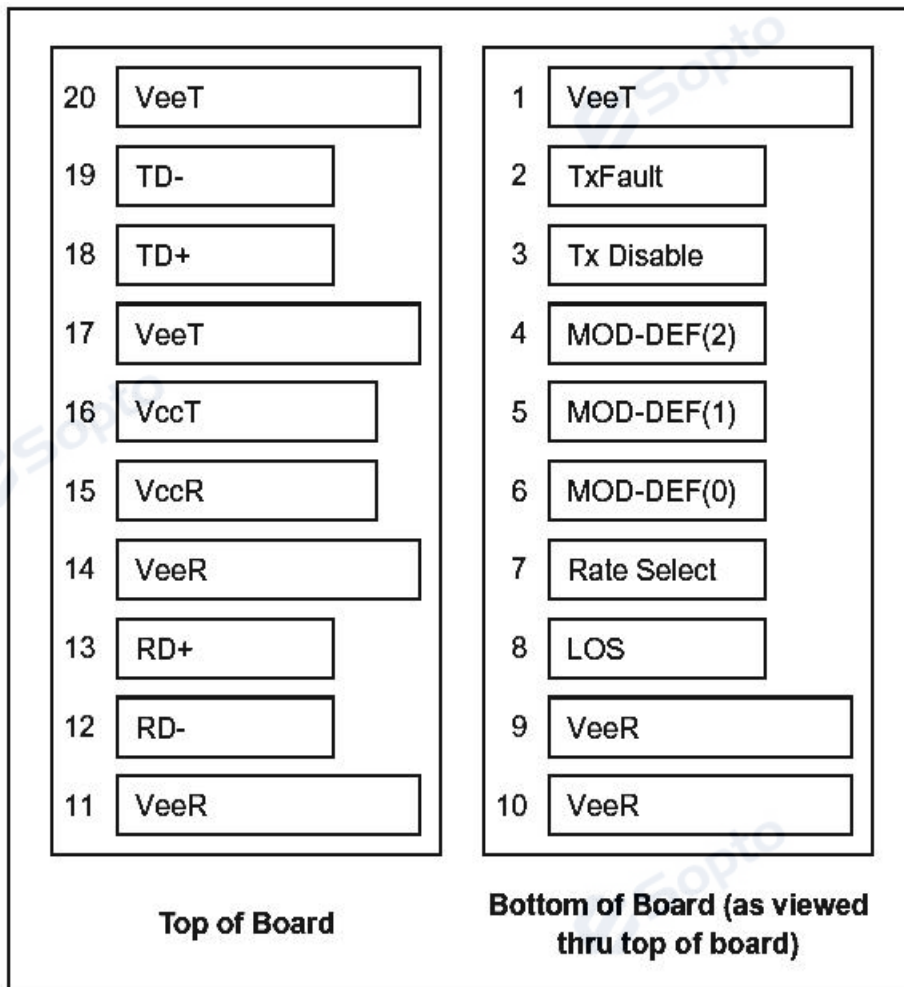



Pin Descriptions

Pin	Signal Name	Description	Plug Seq.	Notes
1	VEET	Transmitter Ground	1	
2	TX FAULT	Transmitter Fault Indication	3	Note 1
3	TX DISABLE	Transmitter Disable	3	Note 2
4	MOD_DEF(2)	SDA Serial Data Signal	3	Note 3
5	MOD_DEF(1)	SCL Serial Clock Signal	3	Note 3
6	MOD_DEF(0)	TTL Low	3	Note 3
7	Rate Select	Not Connected	3	
8	LOS	Loss of Signal	3	Note 4
9	VEER	Receiver ground	1	
10	VEER	Receiver ground	1	
11	VEER	Receiver ground	1	
12	RD-	Inv. Received Data Out	3	Note 5
13	RD+	Received Data Out	3	Note 5
14	VEER	Receiver ground	1	
15	VCCR	Receiver Power Supply	2	
16	VCCT	Transmitter Power Supply	2	
17	VEET	Transmitter Ground	1	
18	TD+	Transmit Data In	3	Note 6
19	TD-	Inv. Transmit Data In	3	Note 6
20	VEET	Transmitter Ground	1	

Notes:

Plug Seq.: Pin engagement sequence during hot plugging.

- 1) TX Fault is an open collector output, which should be pulled up with a 4.7k~10kΩ resistor on the host board to a voltage between 2.0V and Vcc+0.3V. Logic 0 indicates normal operation; Logic 1 indicates a laser fault of some kind. In the low state, the output will be pulled to less than 0.8V.
- 2) TX Disable is an input that is used to shut down the transmitter optical output. It is pulled up within the module with a 4.7k~10kΩ resistor. Its states are:
 Low (0 to 0.8V): Transmitter on
 (>0.8V, < 2.0V): Undefined
 High (2.0 to 3.465V): Transmitter Disabled
 Open: Transmitter Disabled
- 3) Mod-Def 0,1,2. These are the module definition pins. They should be pulled up with a 4.7k~10kΩ resistor on the host board. The pull-up voltage shall be VccT or VccR.
 Mod-Def 0 is grounded by the module to indicate that the module is present
 Mod-Def 1 is the clock line of two wire serial interface for serial ID
 Mod-Def 2 is the data line of two wire serial interface for serial ID
- 4) LOS is an open collector output, which should be pulled up with a 4.7k~10kΩ resistor. Pull up voltage between 2.0V and Vcc+0.3V. Logic 1 indicates loss of signal; Logic 0 indicates normal operation. In the low state, the output will be pulled to less than 0.8V.
- 5) RD-/+ : These are the differential receiver outputs. They are internally AC-coupled 100 differential lines which should be terminated with 100Ω (differential) at the user SERDES.
- 6) TD-/+ : These are the differential transmitter inputs. They are internally AC-coupled, differential lines with 100Ω differential termination inside the module.

Recommended Interface Circuit

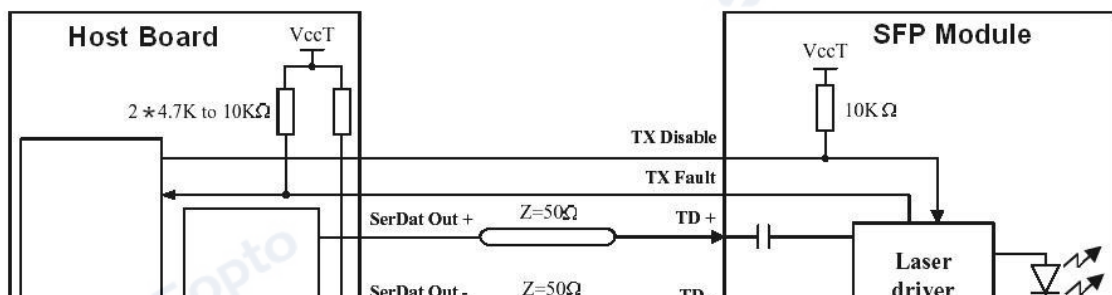



Mechanical Dimensions

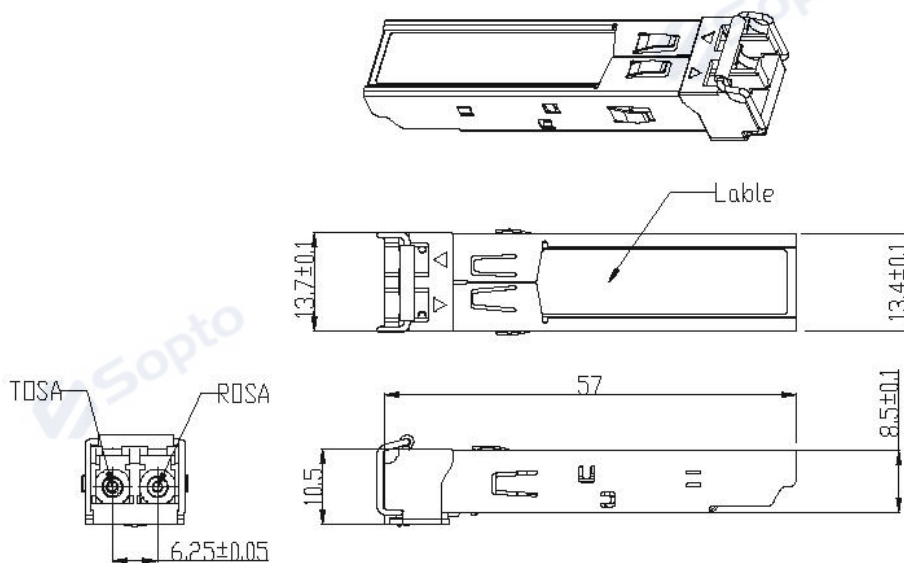

Ordering information

Part Number	Product Description
SPT-P1303-20	1310nm, 155Mbps, 20km, 0°C ~ +70°C
SPT-P1303-20D	1310nm, 155Mbps, 20km, 0°C ~ +70°C, With DDM
SPT-P1303-20T	1310nm, 155Mbps, 20km, -40°C ~ +85°C
SPT-P1303-20TD	1310nm, 155Mbps, 20km, -40°C ~ +85°C, With DDM



Note: If you need more customized services, please contact us.

E-mail: info@sopto.com.cn

Web : <http://www.sopto.com.cn>

