

## 10Gb/s 80km BiDi XFP Transceiver

Hot Pluggable, Single LC, 1490/1570nm, CWDM EML&APD,  
Single mode



### Features

- Supports 9.95Gb/s to 11.3Gb/s bit rates
- Hot-pluggable XFP footprint
- Single LC for Bi-directional Transmission
- Maximum link length of 80km
- Built-in 1490/1570 WDM
- Cooled CWDM EML Laser.
- APD Receiver
- Power dissipation <2W
- No Reference Clock required
- Built-in digital diagnostic functions
- Temperature range 0°C to 70°C
- Very low EMI and excellent ESD protection
- RoHS Compliant Part

### Applications

- 10GBASE-ZR/ZW Ethernet
- SONET OC-192 /SDH

- 10G Fibre Channel

## Description

SOPTO 80km Bi-directional 10Gb/s (XFP) transceivers are compliant with the current XFP Multi-Source Agreement (MSA) Specification. They comply with 10-Gigabit Ethernet 10GBASE-ZR/ZW per IEEE 802.3ae, SONET OC-192 /SDH and 10G Fibre Channel . Digital diagnostics functions are available via a 2-wire serial interface, as specified in the XFP MSA.

## Absolute Maximum Ratings

Parameter	Symbol	Min	Max	Unit
Storage Temperature	T <sub>ST</sub>	-40	+85	°C
Case Operating Temperature	T <sub>IP</sub>	0	+70	°C
Supply Voltage	V <sub>CC3</sub>	-0.5	+4.0	V

## Electrical Characteristics (TOP = 0 to 70 °C)

Parameter	Symbol	Min	Typ	Max	Unit	Note
Supply Voltage	V <sub>CC3</sub>	3.13		3.45	V	
Supply Current	I <sub>CC3</sub>			800	mA	
Module total power	P			2	W	
<b>Transmitter</b>						
Input differential impedance	R <sub>in</sub>		100		Ω	1
Differential data input swing	V <sub>in,pp</sub>	150		820	mV	
Transmit Disable Voltage	V <sub>D</sub>	2.0		V <sub>CC</sub>	V	
Transmit Enable Voltage	V <sub>EN</sub>	GND		GND+0.8	V	
Transmit Disable Assert Time	T <sub>off</sub>			100	ms	
Tx Enable Assert Time	T <sub>on</sub>			100	ms	
<b>Receiver</b>						
Differential data output swing	V <sub>out,pp</sub>	300	500	850	mV	
Data output rise time	t <sub>r</sub>			35	ps	2
Data output fall time	t <sub>f</sub>			35	ps	2
LOS Fault	V <sub>LOS fault</sub>	V <sub>CC</sub> – 0.5		V <sub>CCHOST</sub>	V	3
LOS Normal	V <sub>LOS norm</sub>	GND		GND+0.5	V	3
Power Supply Rejection	PSR		See Note 4 below			4

### Notes

1. After internal AC coupling.

2. 20 – 80 %

3. Loss of Signal is open collector to be pulled up with a 4.7k – 10kohm resistor to 3.15 – 3.6V. Logic 0 indicates normal operation; logic 1 indicates no signal detected.

4. Per Section 2.7.1. in the XFP MSA Specification.

## Optical Parameters(TOP = 0 to 70°C)

Parameter	Symbol	Min	Typ	Max	Unit	Ref.
<b>Transmitter</b>						
Operating Data Rate	BR	9.95		11.3	Gb/s	
Bit Error Rate	BER			$10^{-12}$		
Maximum Launch Power	P <sub>MAX</sub>	1			dBm	1
Optical Center Wavelength	SPT-XB47TG-L80	$\lambda$	1480	1490	1500	nm
	SPT-XB74TG-L80		1560	1570	1580	
Optical Extinction Ratio	ER	5			dB	
Spectral Width	$\Delta\lambda$			1	nm	
Sidemode Supression ratio	SSR <sub>min</sub>	30			dB	
Rise/Fall Time (20%~80%)	Tr/Tf			50	ps	
Average Launch power of OFF Transmitter	P <sub>OFF</sub>			-30	dBm	
Tx Jitter	T <sub>xj</sub>	Compliant with each standard requirements				
Optical Eye Mask		IEEE802.3ae				2
<b>Receiver</b>						
Operating Data Rate	BR	9.95		11.3	Gb/s	
Receiver Sensitivity	Sen			-22	dBm	2
Maximum Input Power	P <sub>MAX</sub>	0			dBm	2
Optical Center Wavelength	SPT-XB47TG-L80	$\lambda_C$	1560	1570	1580	nm
	SPT-XB74TG-L80		1480	1490	1500	
Receiver Reflectance	R <sub>rx</sub>			-27	dB	
LOS De-Assert	LOS <sub>D</sub>			-25	dBm	
LOS Assert	LOS <sub>A</sub>	-36			dBm	
LOS Hysteresis	LOS <sub>H</sub>	0.5		5	dB	

### Notes:

- The optical power is launched into SMF.
- Measured with a PRBS  $2^{31}-1$  test pattern @10.3125Gbps BER< $10^{-12}$ .

## Pin Assignment

Diagram of Host Board Connector Block Pin Numbers and Name

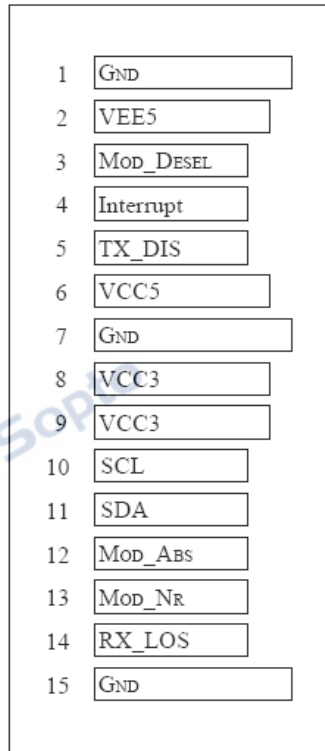

Bottom of Board  
(As view through top of board)

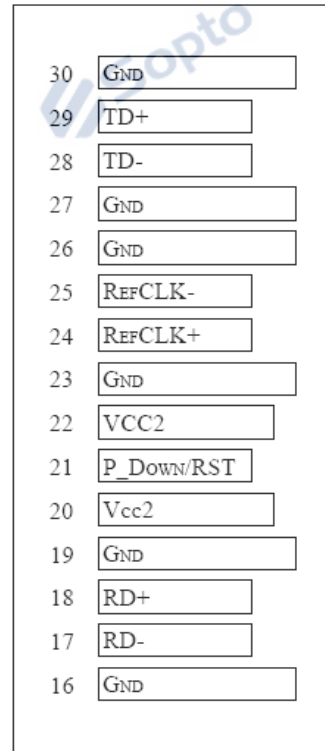

Top of Board

## Pin Function Definitions

Pin	Logic	Symbol	Name/Description	Ref.
1		GND	Module Ground	1
2		VEE5	Optional -5.2 Power Supply – Not required	
3	LVTTL-I	Mod-Desel	Module De-select; When held low allows the module to respond to 2-wire serial interface commands	
4	LVTTL-O	Interrupt	Interrupt (bar); Indicates presence of an important condition which can be read over the serial 2-wire interface	2
5	LVTTL-I	TX_DIS	Transmitter Disable; Transmitter laser source turned off	
6		VCC5	+5 Power Supply	
7		GND	Module Ground	1
8		VCC3	+3.3V Power Supply	
9		VCC3	+3.3V Power Supply	
10	LVTTL-I	SCL	Serial 2-wire interface clock	2
11	LVTTL-I/O	SDA	Serial 2-wire interface data line	2
12	LVTTL-O	Mod_Abs	Module Absent; Indicates module is not present. Grounded in the module.	2
13	LVTTL-O	Mod_NR	Module Not Ready;	2

14	LVTTL-O	RX_LOS	Receiver Loss of Signal indicator	2
15		GND	Module Ground	1
16		GND	Module Ground	1
17	CML-O	RD-	Receiver inverted data output	
18	CML-O	RD+	Receiver non-inverted data output	
19		GND	Module Ground	1
20		VCC2	+1.8V Power Supply – Not required	
21	LVTTL-I	P_Down/R ST	Power Down; When high, places the module in the low power stand-by mode and on the falling edge of P_Down initiates a module reset	
			Reset; The falling edge initiates a complete reset of the module including the 2-wire serial interface, equivalent to a power cycle.	
22		VCC2	+1.8V Power Supply – Not required	
23		GND	Module Ground	1
24	PECL-I	RefCLK+	Reference Clock non-inverted input, AC coupled on the host board – Not required	3
25	PECL-I	RefCLK-	Reference Clock inverted input, AC coupled on the host board – Not required	3
26		GND	Module Ground	1
27		GND	Module Ground	1
28	CML-I	TD-	Transmitter inverted data input	
29	CML-I	TD+	Transmitter non-inverted data input	
30		GND	Module Ground	1

**Note**

1. Module circuit ground is isolated from module chassis ground within the module.
2. Open collector; should be pulled up with 4.7k – 10k ohms on host board to a voltage between 3.15V and 3.45V.
3. A Reference Clock input is not required.

## Digital Diagnostic Functions

As defined by the XFP MSA 1, FTTX's XFP transceivers provide digital diagnostic functions via a 2-wire serial interface, which allows real-time access to the following operating parameters:

- ✓ Transceiver temperature
- ✓ Laser bias current
- ✓ Transmitted optical power
- ✓ Received optical power
- ✓ Transceiver supply voltage

It also provides a sophisticated system of alarm and warning flags, which may be used to alert end-users when particular operating parameters are outside of a factory-set normal range.

The operating and diagnostics information is monitored and reported by a Digital Diagnostics Transceiver Controller (DDTC) inside the transceiver, which is accessed through the 2-wire serial interface. When the serial protocol is activated, the serial clock signal (SCL pin) is generated by the host. The positive edge clocks data into the XFP transceiver into those segments of its memory map that are not write-protected. The negative edge clocks data from the XFP transceiver. The serial data signal (SDA pin) is bi-directional for serial data transfer. The host uses SDA in conjunction with SCL to mark the start and end of serial



protocol activation. The memories are organized as a series of 8-bit data words that can be addressed individually or sequentially. The 2-wire serial interface provides sequential or random access to the 8 bit parameters, addressed from 000h to the maximum address of the memory.

For more detailed information including memory map definitions, please see the XFP MSA Specification.

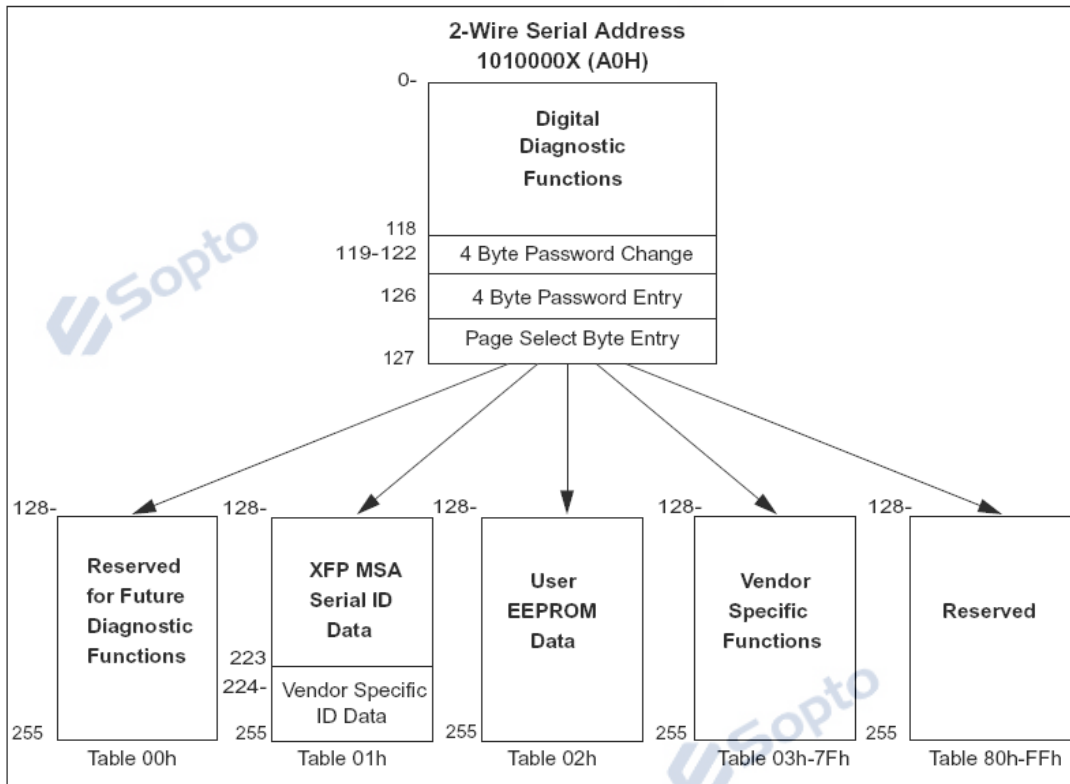

### Recommended Circuit

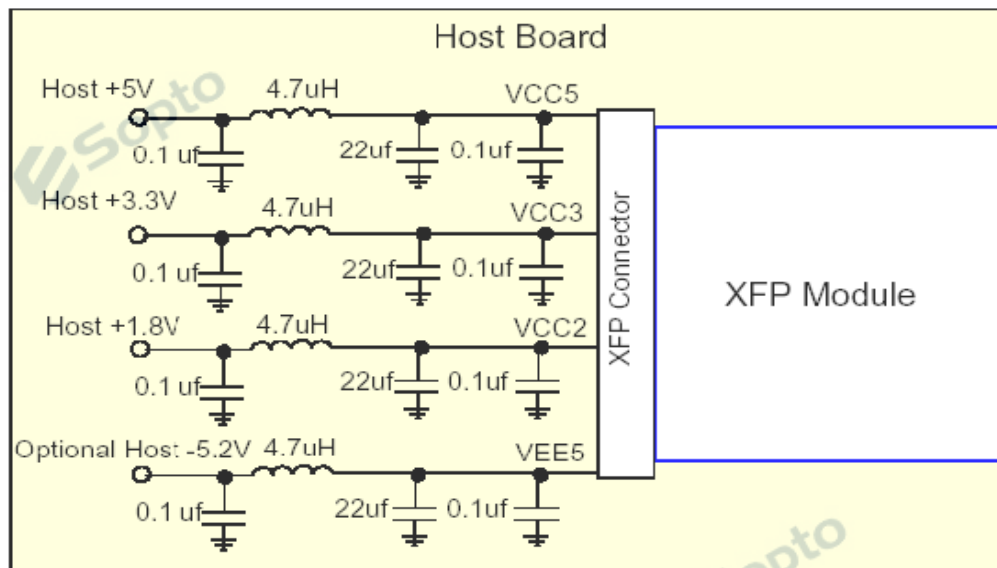

**Recommended Host Board Power Supply Circuit**

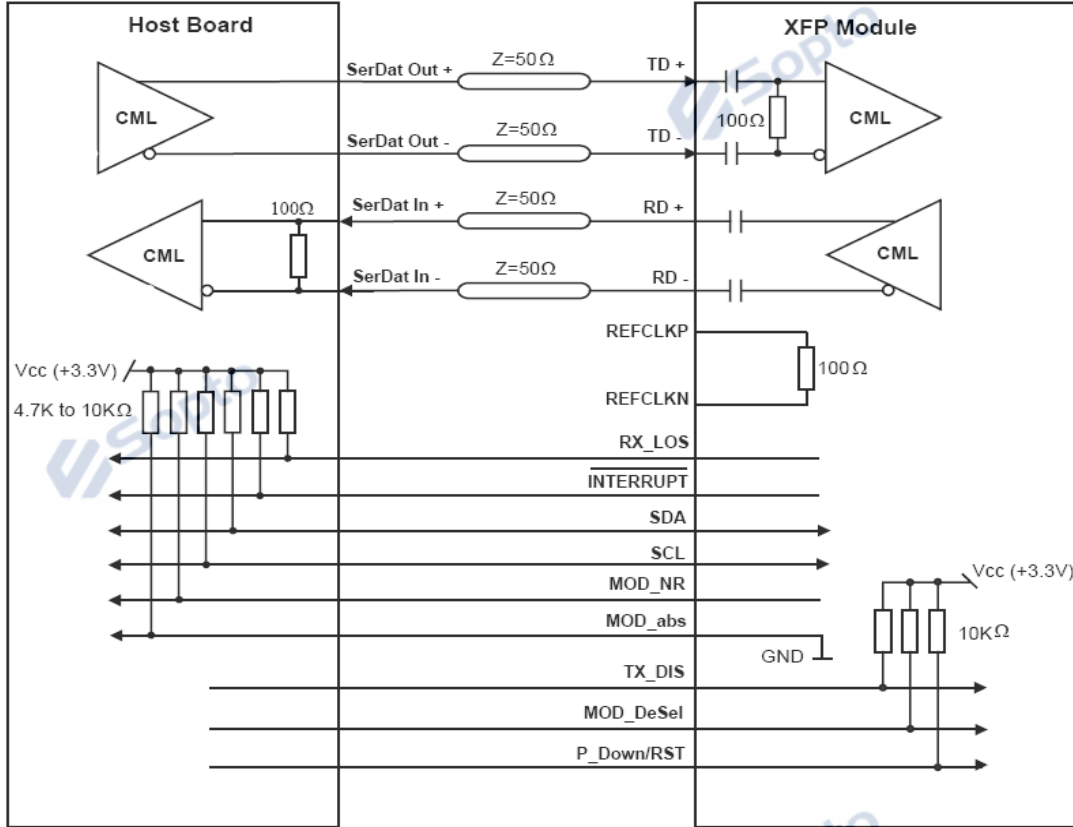

Recommended High-speed Interface Circuit

### Mechanical Dimensions

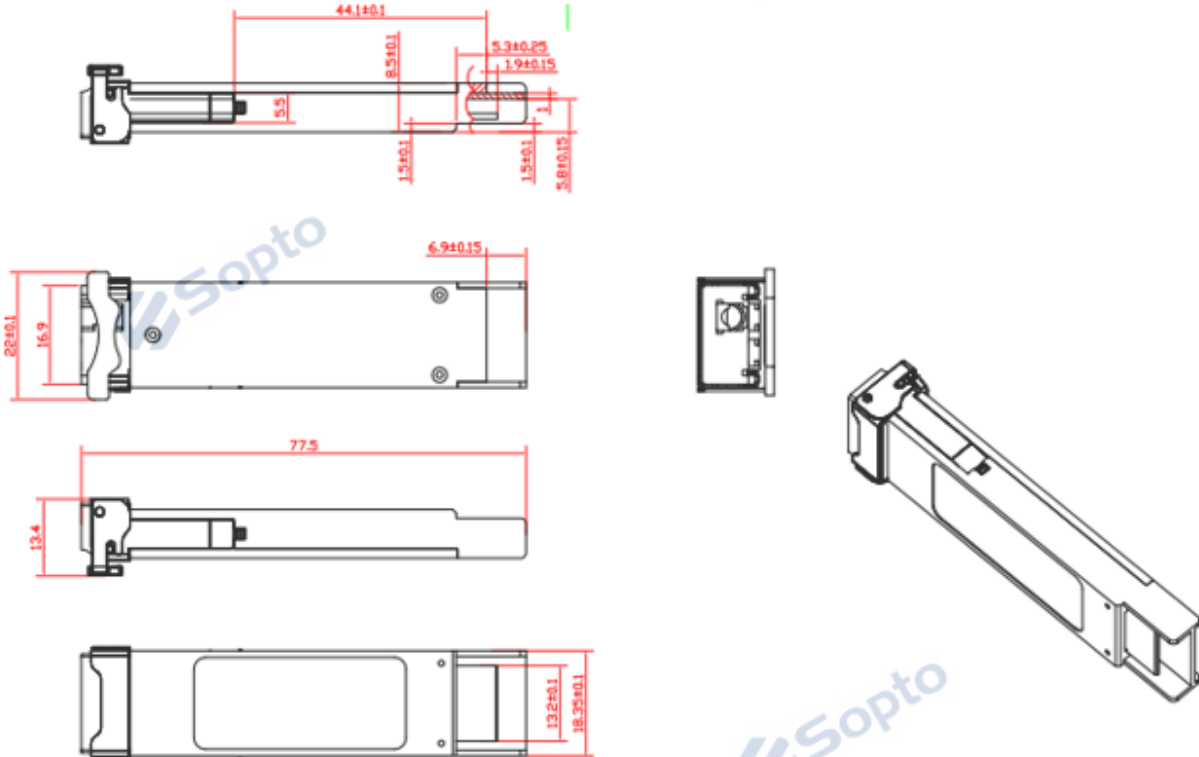

## Ordering information

Part Number	Product Description
SPT-XB47TG-L80	Transceiver XFP Single Fiber BIDI 1490nmTx/1570nmRx 10G LC Connector 80km with DDM Commercial Temperature
SPT-XB74TG-L80	Transceiver XFP Single Fiber BIDI 1570nmTx/1490nmRx 10G LC Connector 80km with DDM Commercial Temperature

Note: If you need more customized services, please contact us.

E-mail: [info@sopto.com.cn](mailto:info@sopto.com.cn)

Web : <http://www.sopto.com.cn>