

SPT-GU3412-SB2BD

GPON ONU SFP ClassB+ Transceiver

Features

- BiDi SFP Single Mode Transceiver
- SC receptacle is optional
- Comply with ITU-T G.984.2 Class B+
- Compliant with SFF MSA-2000 And SFF-8472 V10.3
- Single +3.3 Power Supply
- LVPECL Differential Data Inputs And CML Data Outputs
- LVTTL Signal Detection Output And LVTTL Burst Control
- Complies with Telcordia (Bellcore) GR-468-CORE
- 1310 nm Burst Mode Transmitter and 1490 nm Continuous Mode Receiver
- 1.244 Gbps DFB Laser Diode, 2.488 Gbps APD-TIA Receiver
- Maximal reach 20km

Applications

- GPON ONU For P2MP Application

General

The SOPTO SPT-GU3412-SB2BD transceiver with BIDI SFP package supports typically 1.244 Gbps Tx, 2.488 Gbps Rx Asymmetric Data Rate for GPON ONU application up to 20km transmission distance, it's designed meeting with ITU-T G.984.2 Class B+. SC receptacle is for optical interface.

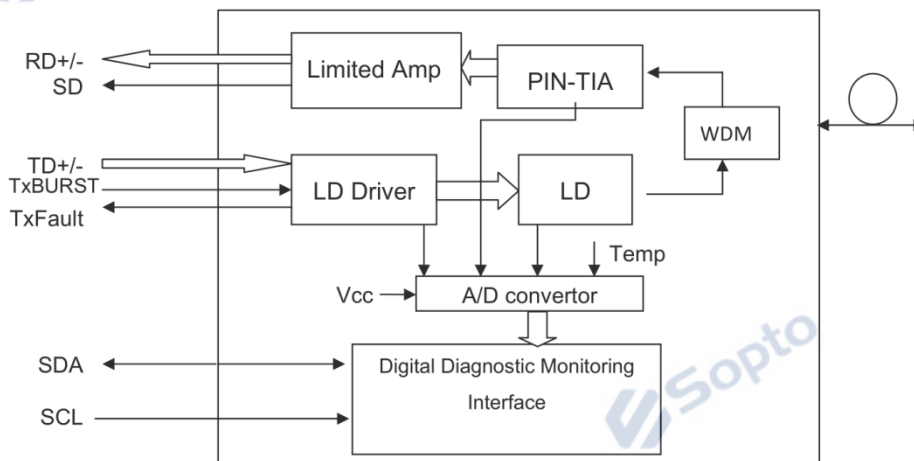

Fig 1 Transceiver Block Diagram

The module provides digital diagnostic information of its operating conditions and status, including transmitting power, laser bias, receiver input optical power, module temperature, and supply voltage. Calibration and alarm/warning threshold data are written and stored in internal memory (EEPROM). The memory map is compatible with SFF-8472, as shown in Fig. 2. The diagnostic data are raw A/D values and must be converted to real world units using calibration constants stored in EEPROM locations 56 – 95 in A2h.

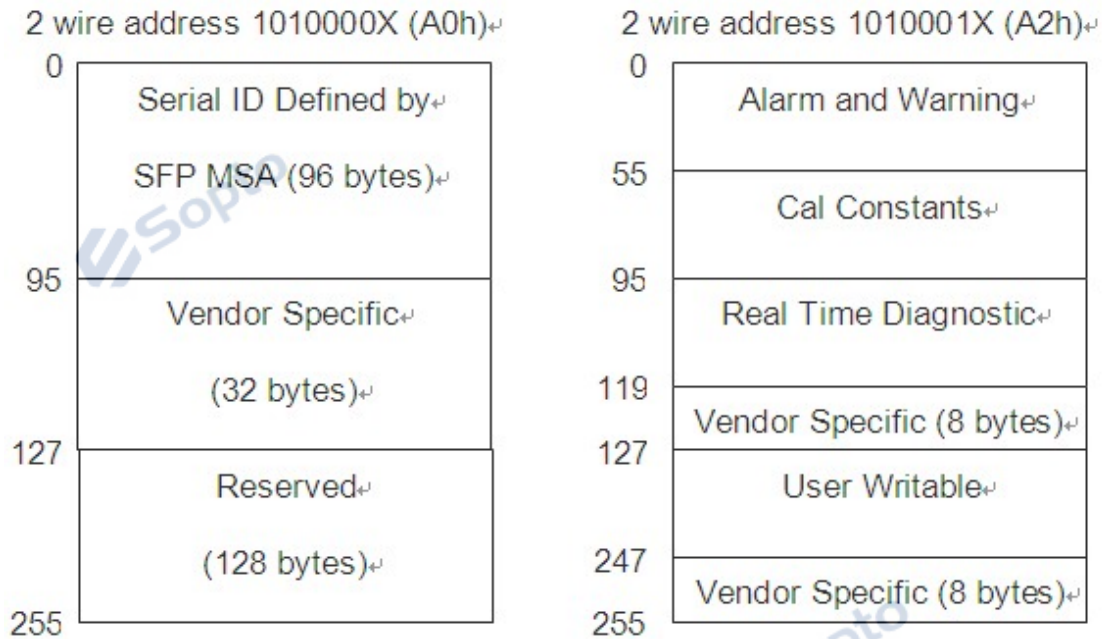

Fig 2 EEPROM Information

Performance Specifications

Absolute Maximum Ratings

Parameter	Symbol	Min.	Max.	Unit	Note
Storage Temperature	Tst	-40	+85	°C	
Operating Case Temperature	Tc	0	70	°C	Standard
		-40	+85		Industrial
Input Voltage	-	GND	Vcc	V	
Power Supply Voltage	Vcc-Vee	-0.5	+3.6	V	
Damage Threshold For Receiver	-	-	4	dBm	
Soldering Temperature / Time	-	-	260/10	°C/S	

Recommended Operating Conditions

Parameter	Symbol	Min.	Typical	Max.	Unit	Note
Power Supply Voltage	Vcc	3.135	3.3	3.465	V	-
Operating Case Temperature	Tc	0	-	70	°C	Standard
		-40	-	85		Industrial
Total Supply Current	-	-	-	350	mA	-

Optical Specification

Transmitter						
Parameter	Symbol	Min.	Typ.	Max.	Unit	Note
Data Rate	DR	-	1.244	-	Gbps	-
Optical Central Wavelength	l	1260	1310	1360	nm	
Spectral Width (-20dB)	DI	-	-	1	nm	
Side Mode Suppression Ratio	SMSR	30	-	-	dB	
Average Optical Output Power	Po	0.5	-	5	dBm	
Extinction Ratio	Er	9	-	-	dB	-
Tx Burst ON Time	Ton	-	-	12.86	ns	-
Tx Burst OFF Time	Toff	-	-	12.86	ns	-
Rise/Fall Time	Tr/Tf	-	-	250	ps	-
Average Launched Power of Off Transmitter	Poff	-	-	-45	dBm	-
Output Eye	Compliant with ITU-T G.984.2					
Receiver						
Parameter	Symbol	Min.	Typ.	Max.	Unit	Note
Data Rate	DR	-	2.488	-	Gbps	-
Operate Wavelength	-	1480	-	1500	nm	-
Sensitivity	Pr	-	-	-28	dBm	1
Saturation	Ps	-8	-	-	dBm	1
SD De-assert Level	-	-45	-	-	dBm	-
SD Assert Level	-	-	-	-28	dBm	-
SD Hysteresis	-	0.5	-	6	dB	-
Optical Return Loss	-	-	-	-12	dB	-
RSSI Range	-	-28	-	-8	dBm	-
RSSI Accuracy	-	-3	-	+3	dB	-

Note:

1. Minimum Sensitivity and saturation levels for a 2²³-1 PRBS. BER ≤ 10⁻¹⁰, 2.488Gbps, ER=9dB

Electrical Specification						
Transmitter						
Parameter	Symbol	Min.	Typ.	Max.	Unit	Note
Differential Input Voltage	V _{IN-DIF}	300	-	1600	mV	-
Tx Burst Input Voltage-Low	V _{IL}	0	-	0.8	V	-
Tx Burst Input Voltage-High	V _{IH}	2.0	-	V _{cc}	V	-
Receiver						
Parameter	Symbol	Min.	Typ.	Max.	Unit	Note
Data Output Voltage Differential	V _{OUT-DIF}	500	-	900	V	-

Signal Detect Output Voltage-Low	VSD-L	0	-	0.8	V	
Signal Detect Output Voltage-High	VSD-H	2.0	-	Vcc	V	-

EEPROM Information

EEPROM Serial ID Memory Contents (A0h)

Addr. (decimal)	Field Size (Bytes)	Name of Field	Content (Hex)	Content (Decimal)	Description
0	1	Identifier	03	3	SFP
1	1	Ext. Identifier	04	4	MOD4
2	1	Connector	01	01	Receptacle
3-10	8	Transceiver	00 00 00 80 00 00 00 00	00 00 00 128 00 00 00 00	Transmitter Code
11	1	Encoding	01	1	8B10B
12	1	BR, nominal	0C	12	1.25Gbps
13	1	Reserved	00	0	-
14	1	Length (9um)-km	14	20	20km
15	1	Length (9um)	C8	200	20km
16	1	Length (50um)	00	0	-
17	1	Length (62.5um)	00	0	-
18	1	Length (copper)	00	0	-
19	1	Reserved	00	0	-
20-35	16	Vendor name	Omitted	Omitted	'SOPTO' (ASCII)
36	1	Reserved	00	0	-
37-39	3	Vendor OUI	00 00 00	0 0 0	-
40-55	16	Vendor PN	Omitted	Omitted	SPT-EU3411-SE 2AD (ASCII)
56-59	4	Vendor rev	30 30 30 20	48 48 48 32	"000" (ASCII)
60-61	2	Wavelength	05 1E	05 30	1310
62	1	Reserved	00	0	-
63	1	CC BASE	-	-	Check sum of bytes 0 - 62
64	1	Reserved	00	0	
65	1	Options	1C	28	
66	1	BR, max	00	0	-
67	1	BR, min	00	0	-
68-83	16	Vendor SN	-	-	ASCII
84-91	8	Vendor date	-	-	Year (2 bytes), Month (2 bytes), Day (2 bytes)
92	1	DDM Type	58/68	88/104	External/Internal Calibrated
93	1	Enhanced Option	B0	176	LOS, TX_FAULT

					and Alarm/warning flags implemented
94	1	SFF-8472 Compliance	03	3	SFF-8472 Rev 10.3
95	1	CC EXT	-	-	Check sum of bytes 64 - 94
96-255	160	Vendor spec			

Alarm and Warning Thresholds (Serial ID A2H)

Parameter(Unit)	C Temp (°C)	I Temp (°C)	Voltage (V)	Bias (mA)	TX Power (dBm)	RX Power (dBm)
High Alarm	100	100	3.6	90	5	-8
Low Alarm	-10	-40	3	0	0.5	-28
High Warning	95	95	3.5	70	4	-9
Low Warning	0	-30	3.1	0	1	-27

Digital Diagnostic Monitor Accuracy

Parameter	Unit	Accuracy	Range	Calibration
Tx Optical Power	dB	±3	Po: -Pomin~Pomax dBm, Recommended operation conditions	External/Internal
Rx Optical Power	dB	±3	Pi: Ps~Pr dBm, Recommended operation conditions	External/Internal
Bias Current	%	±10	Id: 1-100mA, Recommended operating conditions	External/Internal
Power Supply Voltage	%	±3	Recommended operating conditions	External/Internal
Internal Temperature	°C	±3	Recommended operating conditions	External/Internal

PIN Diagram

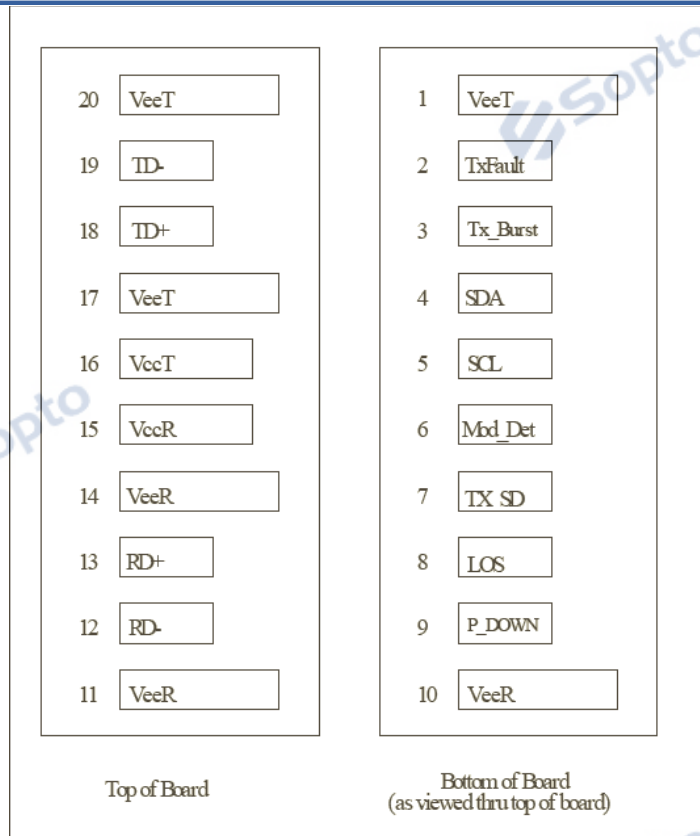

PIN Description

Pin No.	Name	Function	Plug Seq.	Notes
1	VeeT	Transmitter Ground	1	
2	Tx Fault	Transmitter Fault Indication	3	Note 1
3	Tx Burst	Transmitter Burst Mode Control.	3	Note 2
4	SDA	Module Definition 2	3	Note 3
5	SCL	Module Definition 1	3	Note 3
6	MOD-DET	Module Definition 0	3	Note 3
7	TX SD	Tx Transmitter State Indication, assert When Tx ON . Optional	3	
8	LOS	Los Of Signal	3	Note 4
9	P_DOWN	Power Down, NC/High=Normal operation ,Low=Power down. Optional	1	
10	VeeR	Receiver Ground	1	Note 5
11	VeeR	Receiver Ground	1	Note 5
12	RD-	Inv. Receiver Data Out	3	Note 6
13	RD+	Receiver Data Out	3	Note 6
14	VeeR	Receiver Ground	1	Note 5
15	VccR	Receiver Power Supply	2	Note 7, 3.3V± 5%
16	VccT	Transmitter Power Supply	2	Note 7, 3.3V± 5%
17	VeeT	Transmitter Ground	1	Note 5
18	TD+	Transmitter Data In	3	Note 8
19	TD-	Inv.Transmitter Data In	3	Note 8
20	VeeT	Transmitter Ground	1	Note 5

Notes:

- TX Fault is an open collector/drain output, which should be pulled up with a 4.7K–10KΩ resistor on the host board. Pull up voltage between 2.0V and VccT, R+0.3V. When high, output indicates a laser fault of some kind. Low indicates normal operation. In the low state, the output will be pulled to < 0.8V.
- TX Burst is an input that is used to enable/disable the transmitter optical output. Burst Logic ‘1’ or Logic ‘0’ Tx on ,pleaser refer to order information

Logic ‘0’	Low	0 – 0.8V
>0.8, < 2.0V		Undefined
Logic ‘1’	High	2.0 – 3.465V
Open		Undefined
- Mod-Def 0,1,2. These are the module definition pins. They should be pulled up with a 4.7K – 10KΩ resistor on the host board. The pull-up voltage shall be VccT or VccR.
 Mod-Def 0 is grounded by the module to indicate that the module is present
 Mod-Def 1 is the clock line of two wire serial interface for serial ID
 Mod-Def 2 is the data line of two wire serial interface for serial ID
- LOS (Loss of Signal) is an open collector/drain output, which should be pulled up with a 4.7K – 10KΩ resistor. Pull up voltage between 2.0V and VccT, R+0.3V. When high, this output indicates the received optical power is below the worst-case receiver sensitivity (as defined by the standard in use). Low indicates normal operation. In the low state, the output will be pulled to < 0.8V.
- VeeR and VeeT may be internally connected within the SFP module.
- RD-/+ : These are the differential receiver outputs. They are DC coupled 100Ω differential lines which should be terminated with 100Ω (differential) at the user SERDES.
- VccR and VccT are the receiver and transmitter power supplies. They are defined as 3.3V ±5% at the SFP connector pin. Maximum supply current is 450mA. Recommended host board power supply filtering is shown below. Inductors with DC resistance of less than 1Ω should be used in order to maintain the required voltage at the SFP input pin with 3.3V supply voltage. When the recommended supply filtering network is used, hot plugging of the SFP transceiver module will result in an inrush current of no more than 30 mA greater than the steady state value. VccR and VccT may be internally connected within the SFP transceiver module.
- TD-/+ : These are the differential transmitter inputs. They are DC-coupled, differential lines with 100Ω differential termination inside the module.

Recommended Interface Circuit

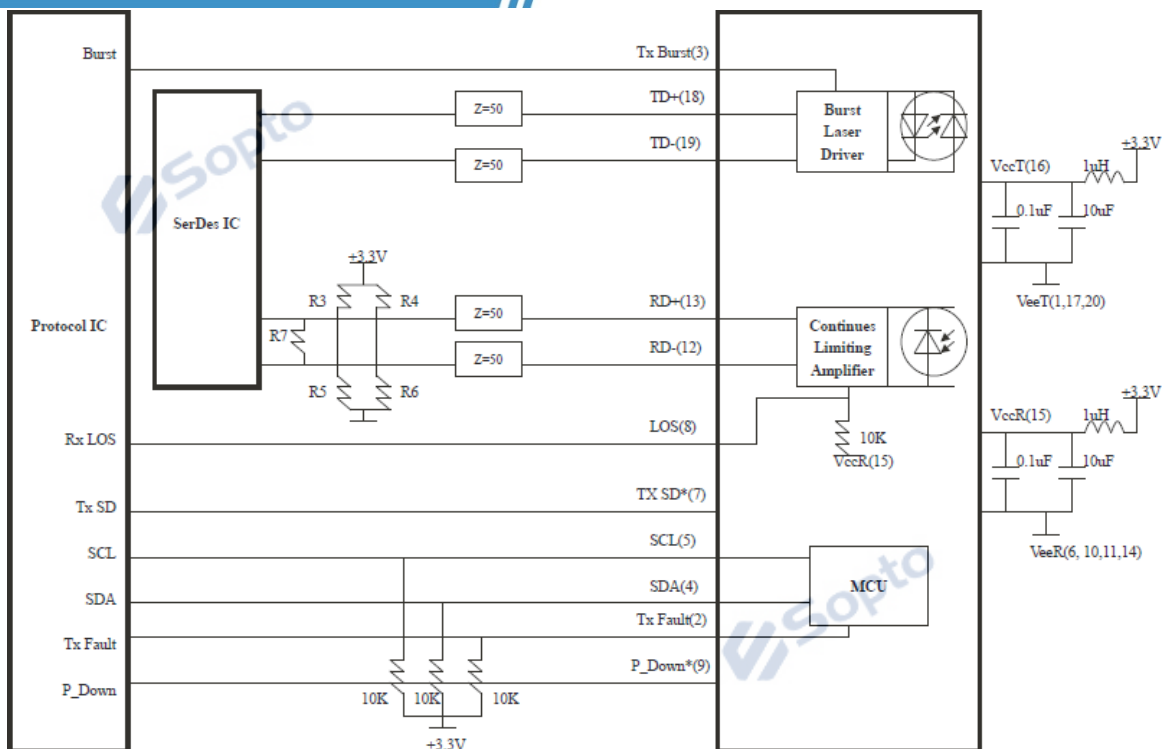

Note:

Tx: DC coupled internally.

Rx: AC coupled internally.

Input stage in SerDes IC with internal bias to $V_{cc}-1.3V$ $R3=R4=R5=R6=N.C$, $R7=100\Omega$

Input stage in SerDes IC without internal bias to $V_{cc}-1.3V$ $R3=R4=82\Omega$, $R5=R6=130\Omega$, $R7=N.C$

Burst Mode Sequence Definition

Tx Burst control: Logic '1' Tx ON

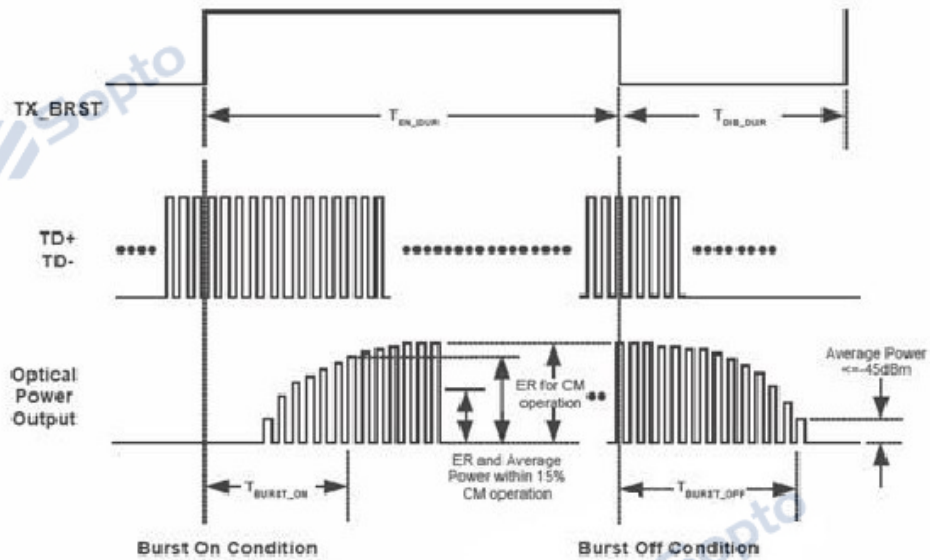

Tx Burst control: Logic '0' Tx ON

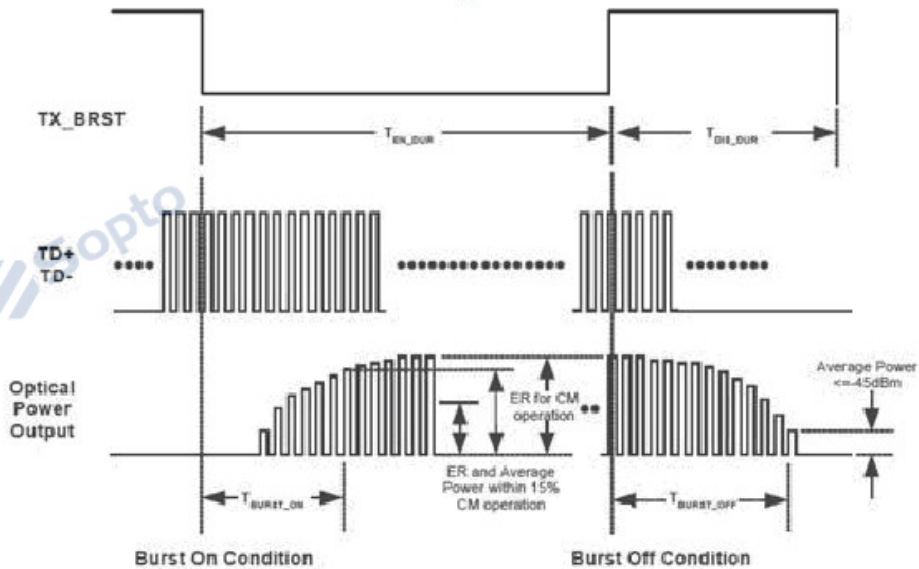

Mechanical Dimensions

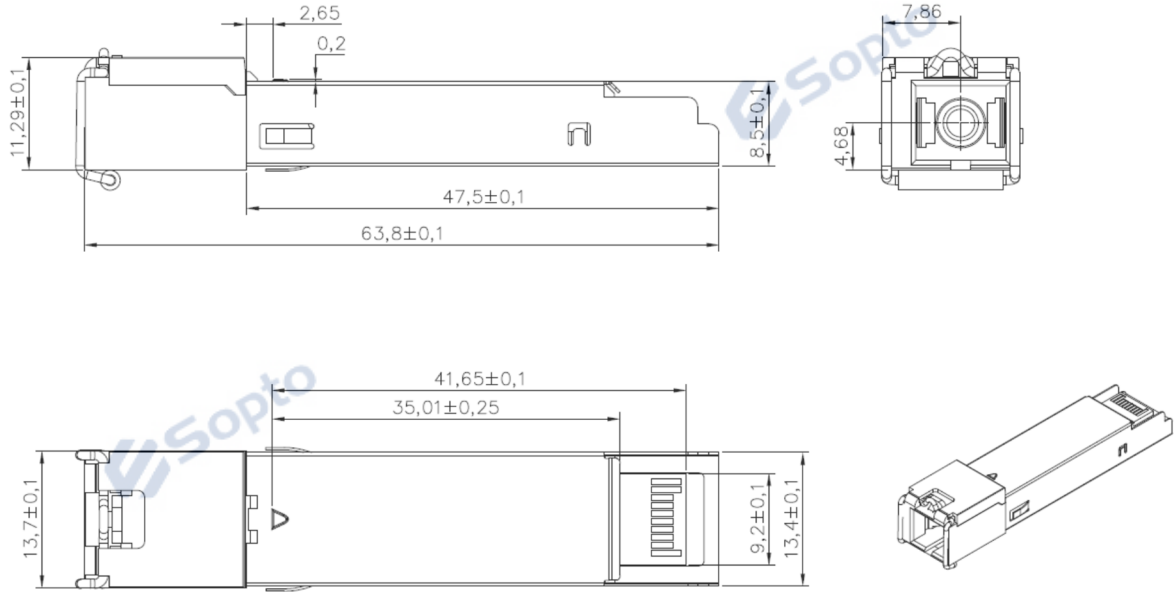

Unit: mm

Ordering information

Ordering P/Ns	Description
SPT-GU3412-SB2BD-1	GPON ONU SFP Transceiver 1310nmTx/1490nmRx 1.244G/2.488G SC Interface Class B+ with DDM Commercial Temperature Burst Logic 1 Tx On , with TxSD
SPT-GU3412-SB2BD-0	GPON ONU SFP Transceiver 1310nmTx/1490nmRx 1.244G/2.488G SC Interface Class B+ with DDM Commercial Temperature Burst Logic 0 Tx On , with TxSD

E-mail: info@sopto.com.cn

Web : <http://www.sopto.com.cn>