

# SPT-P856G-S3D

850nm 4.9G/6.144Gbps SFP+ Transceiver 300m for CPRI and OBSAI

## Features

- Support Multi Rate up to 4.9G/6.144Gbps
- CPRI/OBSAI Compatible Optical Interface
- Hot Pluggable SFP+ footprint
- 850nm VCSEL transmitter, PIN photo-detector
- Transmission distance up to 300m with MMF
- Digital Status monitoring Interface
- Duplex LC connector
- RoHS compliant and lead Free
- Metal enclosure for lower EMI
- Single 3.3V power supply
- Power dissipation <800mW
- Compliant with FC-PI-4 800-MX-SN,SFF-8431,SFF-8432 and SFF-847
- Operating case temperature:
  - Standard: 0 to +70°C
  - Extend: -20 to 85°C
  - Industrial: -40 to +85°C

## Applications

- Radio Base Station
- LTE optical repeater application
- OBSAI interface, such as 6.144/1.536/3.072/1.536Gbps and 768Mbps
- CPRI interface, such as 6.144/3.072/2.4576/1.228Gbps and 614Mbps

## Description

This 850 nm VCSEL SFP+ transceiver is designed to transmit and receive optical data over 50/125  $\mu\text{m}$  or 62.5/125  $\mu\text{m}$  multimode optical fiber (Table 1).

Fiber type	Minimum modal bandwidth@850nm(MHz*km)	Operating range (meters)
62.5um MMF	160	2 to 26
	200	2 to 33
50 μm MMF	400	2 to 66
	500	2 to 82
	2000	2 to 300

**Table 1: 6G SFP+ S3 Operating Range for each Optical Fiber Type**

SPT-P856G-S3D is a high performance, cost effective modules for serial optical data communications such as CPRI and OBSAI, which is supporting Multi Rate Up to 4.9G/6.144Gbps, and transmission distance up to 300m on MM fiber.

The SFP+ SR module electrical interface is compliant to SFI electrical specifications. The transmitter input and receiver output impedance is 100 Ohms differential. Data lines are internally AC coupled. The module provides differential termination and reduce differential to common mode conversion for quality signal termination and low EMI. SFI typically operates over 200 mm of improved FR4 material or up to about 150mm of standard FR4 with one connector.

The transmitter converts 6G serial PECL or CML electrical data into serial optical data compliant with the 10GBASE-SR standard. An open collector compatible Transmit Disable (Tx\_Dis) is provided. A logic “1,” or no connection on this pin will disable the laser from transmitting. A logic “0” on this pin provides normal operation. The transmitter has an internal automatic power control loop (APC) to ensure constant optical power output across supply voltage and temperature variations. An open collector compatible Transmit Fault (TFault) is provided. TX\_Fault is a module output contacts that when high, indicates that the module transmitter has detected a fault condition related to laser operation or safety. The TX\_Fault output contact is an open drain/collector and shall be pulled up to the Vcc\_Host in the host with a resistor in the range 4.7-10 kΩ. TX\_Disable is a module input contact. When TX\_Disable is asserted high or left open, the SFP+ module transmitter output shall be turned off. This contact shall be pulled up to VccT with a 4.7 kΩ to 10 kΩ resistor

The receiver converts 6G serial optical data into serial PECL/CML electrical data. An open collector compatible Loss of Signal is provided. Rx\_LOS when high indicates an optical signal level below that specified in the relevant standard. The Rx\_LOS contact is an open drain/collector output and shall be pulled up to Vcc\_Host in the host with a resistor in the range 4.7-10 kΩ, or with an active termination. Power supply filtering is recommended for both the transmitter and receiver. The Rx\_LOS signal is intended as a preliminary indication to the system in which the SFP+ is installed that the received signal strength is below the specified range. Such an indication typically points to non-installed cables, broken cables, or a disabled, failing or a powered off transmitter at the far end of the cable.

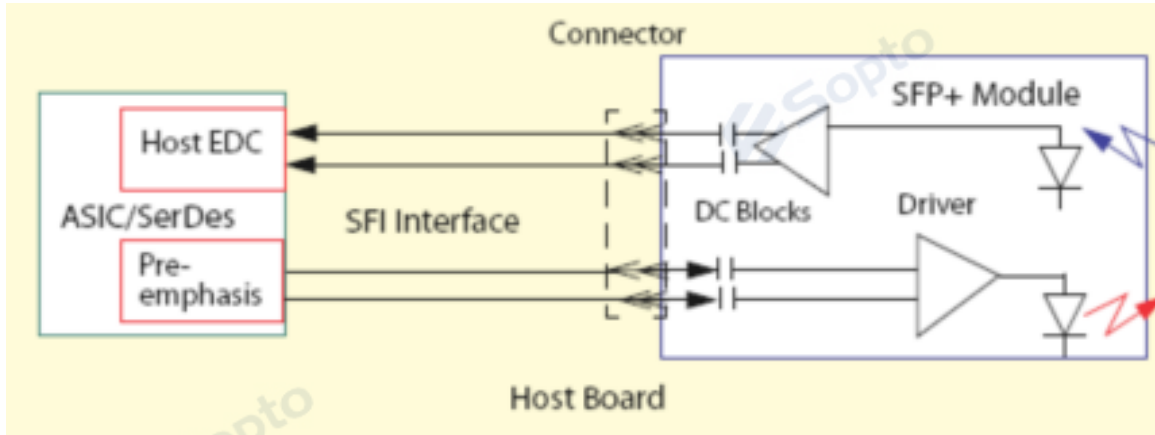

### Pin Assignment

The SFP+ modules are hot-pluggable. Hot pluggable refers to plugging in or unplugging a module while the host board is powered. The SFP+ host connector is a 0.8 mm pitch 20 position right angle improved connector specified by SFF-8083, or stacked connector with equivalent with equivalent electrical performance.

11	VEER	VEER	10
		RS1	9
12	RD-	Rx_LOS	8
13	RD+	RS0	7
14	VEER	Mod_ABS	6
15	VccR	SCL	5
16	VccT	SDA	4
17	VEET	TX_DISABLE	3
18	TD+	TX_FAULT	2
19	TD-	VEET	1
20	VEET		

← TOWARD HOST WITH DIRECTION OF MODULE INSERTION

TOWARD BEZEL →

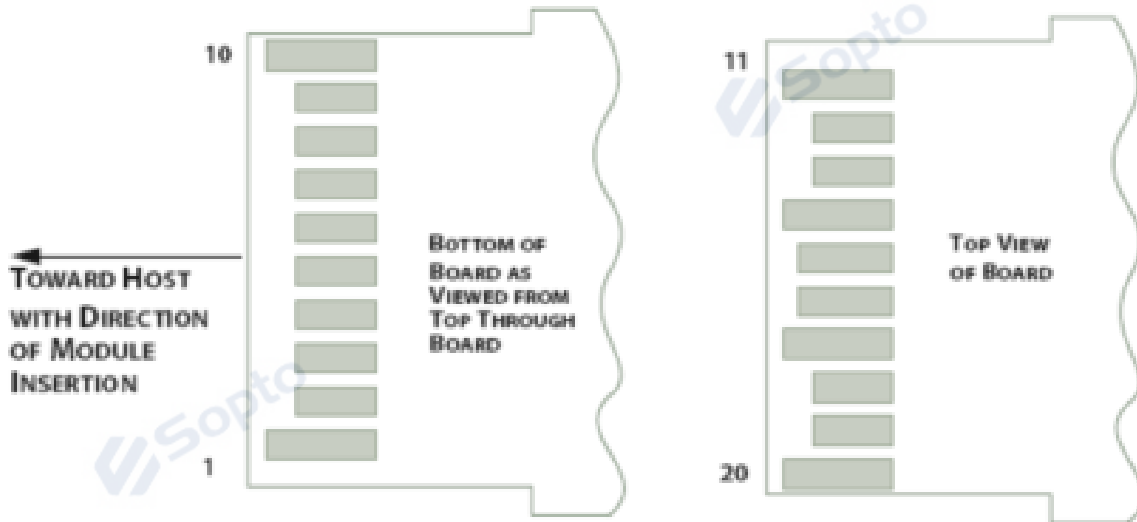

Contacts	logic	Symbol	Power Sequence Order	Name/Description
1		VeeT	1st	Module Transmitter Ground
2	LVTTL-O	TX_Fault	3rd	Module Transmitter Fault
3	LVTTL-I	TX_Disable	3rd	Transmitter Disable; Turns off transmitter laser output
4	LVTTL-I/O	SDA	3rd	2-wire Serial Interface Data Line (Same as MOD-DEF2 in the INF-8074i)
5	LVTTL-I/O	SCL	3rd	2-wire Serial Interface Clock (Same as MOD-DEF1 in the INF-8074i)
6		Mod_ABS	3rd	Module Absent, connected to VeeT or VeeR in the module
7	LVTTL-I	RS0	3rd	Rate Select 0, optionally controls SFP+ module receiver. When high input signaling rate > 4.25 GBd and when low input signaling rate ≤ 4.25 GBd.
8	LVTTL-O	Rx_LOS	3rd	Receiver Loss of Signal Indication (In FC designated as Rx_LOS and in Ethernet designated as Signal Detect)
9	LVTTL-I	RS1	3rd	Rate Select 1, optionally controls SFP+ transmitter. When high input signaling rate > 4.25 GBd and when low input signaling rate ≤ 4.25 GBd.
10		VeeR	1st	Module Receiver Ground
11		VeeR	1st	Module Receiver Ground
12	CML-O	RD-	3rd	Receiver Inverted Data Output
13	CML-O	RD+	3rd	Receiver Non-Inverted Data Output
14		VeeR	1st	Module Receiver Ground
15		VccR	2nd	Module Receiver 3.3 V Supply
16		VccT	2nd	Module Transmitter 3.3 V Supply
17		VeeT	1st	Module Transmitter Ground
18	CML-I	TD+	3rd	Transmitter Non-Inverted Data Input
19	CML-I	TD-	3rd	Transmitter Inverted Data Input
20		VeeT	1st	Module Transmitter Ground

### Absolute Maximum Rating

These values represent the damage threshold of the module. Stress in excess of any of the individual Absolute Maximum Ratings can cause immediate catastrophic damage to the module even if all other

parameters are within Recommended Operating Conditions.

Parameters	Symbol	Min.	Max.	Unit
Power Supply Voltage	VCC	0	+3.6	V
Storage Temperature	Tc	-40	+85	°C
Operating Case Temperature	Tc	0	+70	°C
Relative Humidity	RH	5	95	%
RX Input Average Power	Pmax	-	0	dBm

### Recommended operating environment

Recommended Operating Environment specifies parameters for which the electrical and optical Characteristics hold unless otherwise noted.

Parameter	Symbol	Min	Typical	Max	Unit
Power Supply Voltage	Vcc	3.315	3.300	3.465	V
	Icc			300	mA
Operating Case Temperature	Tc	0	25	70	°C
	Tc	-40	25	85	°C
Power Dissipation	PD			1	W
Data Rate	CPRI/OBSAI			6.25	Gbps
Transmission Distance				300	m

### Optical characteristics

The following optical characteristics are defined over the Recommended Operating Environment unless otherwise specified.

Parameter	Symbol	Min.	Typical	Max	Unit	Ref
<b>Transmitter</b>						
Center Wavelength	$\lambda_t$	840	850	860	nm	
RMS spectral width	Pm		-	Note 1	nm	
Average Optical Power	Pavg	-5	-	-1	dBm	2
Extinction Ratio	ER	3	-	-	dB	3
Transmitter Dispersion Penalty	TDP	-	-	3.9	dB	
Relative Intensity Noise	Rin	-	-	-128	dB/Hz	12dB reflection
Optical Return Loss Tolerance		-	-	12	dB	
<b>Receiver</b>						
Center Wavelength	$\lambda_r$	840	850	860	nm	
Receiver Sensitivity	Psens	-	-	-11	dBm	4

Stressed Sensitivity in OMA		-	-	-8	dBm	4
Los function	Los	-30	-	-12	dBm	
Overload	Pin	-	-	0	dBm	4
Receiver Reflectance		-	-	-12	dB	
LOS De-Assert	LOSD			-13	dBm	

Note:

1. Trade-offs are available between spectral width, center wavelength and minimum OMA, as shown in table 6.
2. The optical power is launched into MMF
3. Measured with a PRBS 2<sup>7</sup>-1 test pattern @8.5Gbps
4. Measured with a PRBS 2<sup>7</sup>-1 test pattern @8.5Gbps, BER≤10<sup>-12</sup>

## Digital Diagnostic Functions

The following digital diagnostic characteristics are defined over the Recommended Operating Environment unless otherwise specified. It is compliant to SFF8472 Rev9.2 with internal calibration mode. For external calibration mode please contact our sales staff.

Parameter	Symbol	Min.	Max.	Units	Notes
Temperature monitor absolute error	DMI_Temp	-3	+3	degC	Over operating temp
Laser power monitor absolute error	DMI_TX	-3	+3	dB	
RX power monitor absolute error	DMI_RX	-3	+3	dB	-3dBm to -12dBm range
Supply voltage monitor absolute error	DMI_VCC	-0.08	-0.08	V	Full operating range
Bias current monitor	DMI_Ibias	-10%	-10%	mA	

## Electrical characteristics

The following electrical characteristics are defined over the Recommended Operating Environment unless otherwise specified.

Parameter	Symbol	Min.	Typical	Max	Unit	Notes
Data Rate	PD			6.25	Gbps	
Power Consumption	CPRI/OBSAI			800	mW	
<b>Transmitter</b>						

Single Ended Output Voltage Tolerance		-0.3		4.0	V	
C common mode voltage tolerance		15			mV	
Tx Input Diff Voltage	VI	400		1200	mV	
Tx Fault	VoL	-0.3		0.4	V	At0.7mA
Data Dependent Input Jitter	DDJ			0.10	UI	
Data Input Total Jitter	TJ			0.28	UI	
<b>Receiver</b>						
Single Ended Output Voltage Tolerance		-0.3		4.0	V	
Rx Output Diff Voltage	Vo	300		850	Mv	
Rx Output Rise and Fall Time	Tr/Tf	30			Ps	20% to 80%
Total Jitter	TJ			0.70	UI	
Deterministic Jitter	DJ			0.42	UI	

### Control and status I/O timing characteristics

Timing characteristics of control and status I/O are included in Table 8, which is also defined in SFF-8431.

Parameter	Symbol	Min.	Max.	Unit	Conditions
TX_Disable assert time	t_off		100	μs	rising edge of TX_Disable to fall of output signal below 10% of nominal
TX_Disable negate time	t_on		2	ms	Falling edge of Tx_Disable to rise of output signal above 90% of nominal. This only applies in normal operation, not during start up or fault recovery.
Time to initialize 2-wire interface	t_2w_start_up		300	ms	From power on or hot plug after the supply meeting <a href="#">Table 8</a> .
Time to initialize	t_start_up		300	ms	From power supplies meeting <a href="#">Table 8</a> or hot plug or Tx disable negated during power up, or Tx_Fault recovery, until non-cooled power level I part (or non-cooled power level II part already enabled at power level II for Tx_Fault recovery) is fully operational.
Time to initialize cooled module	t_start_up_cooled		90	s	From power supplies meeting <a href="#">Table 8</a> or hot plug, or Tx disable negated during power up or Tx_Fault recovery, until cooled power level I part (or cooled power level II part during fault recovery) is fully operational.
Time to Power Up to Level II	t_power_level2		300	ms	From falling edge of stop bit enabling power level II until non-cooled module is fully operational
Time to Power Down from Level II	t_power_down		300	ms	From falling edge of stop bit disabling power level II until module is within power level I requirements
TX_Fault assert	TX_Fault_on		1	ms	From occurrence of fault to assertion of TX_Fault
TX_Fault assert for cooled module	TX_Fault_on_cooled		50	ms	From occurrence of fault to assertion of TX_Fault
TX_Fault Reset	t_reset	10		μs	Time TX_Disable must be held high to reset TX_Fault
RS0, RS1 rate select timing for FC	t_RS0_FC, RS1_FC		500	μs	From assertion till stable output
RS0, RS1 rate select timing non FC	t_RS0, t_RS1		10	ms	From assertion till stable output
Rx_LOS assert delay	t_los_on		100	μs	From occurrence of loss of signal to assertion of Rx_LOS
Rx_LOS negate delay	t_los_off		100	μs	From occurrence of presence of signal to negation of Rx_LOS

## Mechanical Dimensions



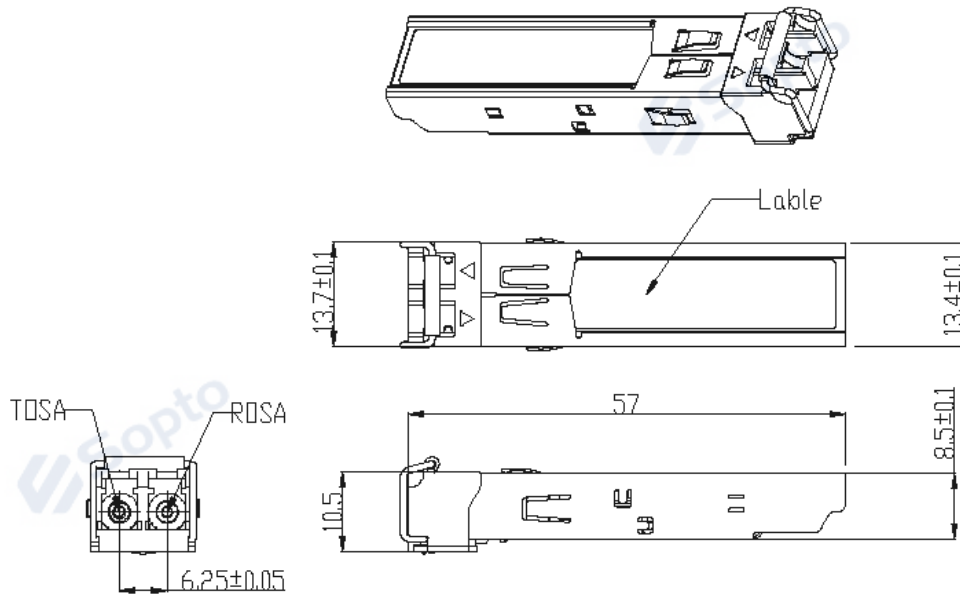

Unit:mm

## ESD

This transceiver is specified as ESD threshold 2kV for all electrical input pins, tested per MIL-STD-883, Method 3015.4 /JESD22-A114-A (HBM). However, normal ESD precautions are still required during the handling of this module. This transceiver is shipped in ESD protective packaging. It should be removed from the packaging and handled only in an ESD protected environment.

## Laser Safety

This is a Class 1 Laser Product according to IEC 60825-1:1993+A1:1997+A2:2001. This product complies with 21 CFR 1040.10 and 1040.11 except for deviations pursuant to Laser Notice No. 50, dated (July 26, 2001)

## Ordering information

Part Number	Product Description
SPT-P856G-S3D	850nm, 4.9G/6.144Gbps, SFP+ 300m, DDM,0°C ~ +70°C
SPT-P856G-S3TD	850nm, 4.9G/6.144Gbps, SFP+ 300m, DDM,-40°C ~ +85°C

E-mail: [info@sopto.com.cn](mailto:info@sopto.com.cn)

Web : <http://www.sopto.com.cn>