

SPT-P1348-10(D)

2.5Gb/s 10km SFP Transceiver (Multi-rate)
Hot Pluggable, Duplex LC, +3.3V, 1310nm, DFB-LD, Single-mode, DDM

Features

- Up to 2.67Gb/s Data Links
- Hot-Pluggable
- Duplex LC connector
- Up to 10km on 9/125 μ m SMF
- 1310nm DFB laser transmitter
- Single +3.3V Power Supply
- Monitoring Interface Compliant with SFF-8472
- Maximum Power <1W
- Industrial operating temperature range: -40°C to 85°C Version available
- RoHS compliant and Lead Free

Applications

- SONET OC-48 / SDH STM -16
- SONET OC-12 / SDH STM -4
- SONET OC-3 / SDH STM -1
- Gigabit Ethernet
- 1x/2xFibre Channel

Description

This SFP transceiver is a high performance, cost effective module which have a duplex LC optics interface. They are compatible with the Small Form Factor Pluggable Multi-Sourcing Agreement (MSA) and Digital diagnostics functions are available via the 2-wire serial bus specified in SFF-8472. The receiver section uses a PIN receiver and the transmitter uses a 1310 nm DFB laser, up to 13dB link budge ensure this module SONET OC-48 / SDH STM -16 10km application.

Absolute Maximum Ratings

Parameter	Symbol	Min	Max	Unit
-----------	--------	-----	-----	------

Supply Voltage	Vcc	-0.5	4	V
Storage Temperature	Ts	-40	+85	°C
Relative Humidity	RH	5	85	%

Recommended Operating Conditions

Parameter	Symbol	Min	Typical	Max	Unit	
Operating Case Temperature	Standard	Tc	0		+70	°C
	Industrial		-40		+85	°C
Supply Voltage	VCC	3.135		3.465	V	
Supply Current	Icc			300	mA	
Inrush Current	Isurge			Icc+30	mA	
Maximum Power	Pmax			1	W	

Electrical Characteristics(TOP = -40 to 85°C, VCC = 3.135 to 3.465 Volts)

Parameter	Symbol	Min.	Typical	Max.	Unit	Note
Transmitter Section:						
Input differential impedance	R _{in}	90	100	110	Ω	1
Single ended data input swing	V _{in PP}	250		1200	mVp-p	
Transmit Disable Voltage	V _D	Vcc - 1.3		Vcc	V	2
Transmit Enable Voltage	V _{EN}	Vee		Vee+ 0.8	V	
Transmit Disable Assert Time	T _{dessert}			10	us	
Receiver Section:						
Single ended data output swing	V _{out,pp}	300		800	mv	3
LOS Fault	V _{losfault}	Vcc - 0.5		V _{CC_host}	V	5
LOS Normal	V _{los norm}	V _{ee}		V _{ee} +0.5	V	5
Power Supply Rejection	PSR	100			mVpp	6

Note:

1. AC coupled.
2. Or open circuit.
3. Into 100 ohm differential termination.
4. 20 - 80 %
5. LOS is LVTTTL. Logic 0 indicates normal operation; logic 1 indicates no signal detected.
6. All transceiver specifications are compliant with a power supply sinusoidal modulation of 20 Hz to 1.5MHz up to specified value applied through the power supply filtering network shown on page 23 of the Small Form-factor Pluggable (SFP) Transceiver Multi-Source Agreement (MSA), September 14, 2000.

Optical Parameters(TOP = -40 to 85°C, VCC = 3.135 to 3.465 Volts)

Parameter	Symbol	Min.	Typical	Max.	Unit	Note
Transmitter Section:						

Center Wavelength	λ_c	1280	1310	1355	nm	
Spectral Width@-20dBm	σ			1	nm	
Sidemode Supression ratio	SSR _{min}	30			dB	
Optical Output Power	P _{out}	-1		-3	dBm	1
Extinction Ratio	ER	9			dB	
Optical Rise/Fall Time	t _r / t _f			260	ps	2
Relative Intensity Noise	RIN			-120	dB/Hz	
Total Generated Transmitter Jitter (peak to peak)	J _{TXp-p}			0.07	UI	
Total Generated Transmitter Jitter (rms)	J _{TXrms}			0.007	UI	
Output Eye Mask	Compliant with eye mask Telcordia GR-253-GORE					
Receiver Section:						
Optical Input Wavelength	λ_c	1270		1600	nm	
RX Sensitivity @ OC-48/STM-16	Sen ₁			-23	dBm	3
RX Sensitivity @ 2xFibre channel	Sen ₂			-23	dBm	4
RX Sensitivity @ Gigabit Ethernet	Sen ₃			-24	dBm	4
RX Sensitivity @ OC-12/STM-4	Sen ₄			-24	dBm	5
RX Sensitivity @ OC-4/STM-1	Sen ₅			-25	dBm	5
RX_LOS Assert	LOS _A	-36			dBm	
RX_LOS De-assert	LOS _D			-25	dBm	
RX_LOS Hysteresis	LOS _H	0.5			dB	
Receiver Overload	P _{ol}	0			dBm	
General Specifications:						
Data Rate	BR	155		2667	Mb/s	
Bit Error Rate	BER			10 ⁻¹²		

Note:

1. Compliant with FDA/CDRH and EN (IEC) 60825 regulations (Class 1 Laser Safety).
2. 20-80%.
3. Measured with PRBS 2³¹-1 at 10⁻¹² BER
4. Measured with PRBS 2⁷-1 at 10⁻¹² BER
5. Measured with PRBS 2²³-1 at 10⁻¹² BER

Pin Assignment

Diagram of Host Board Connector Block Pin Numbers and Name

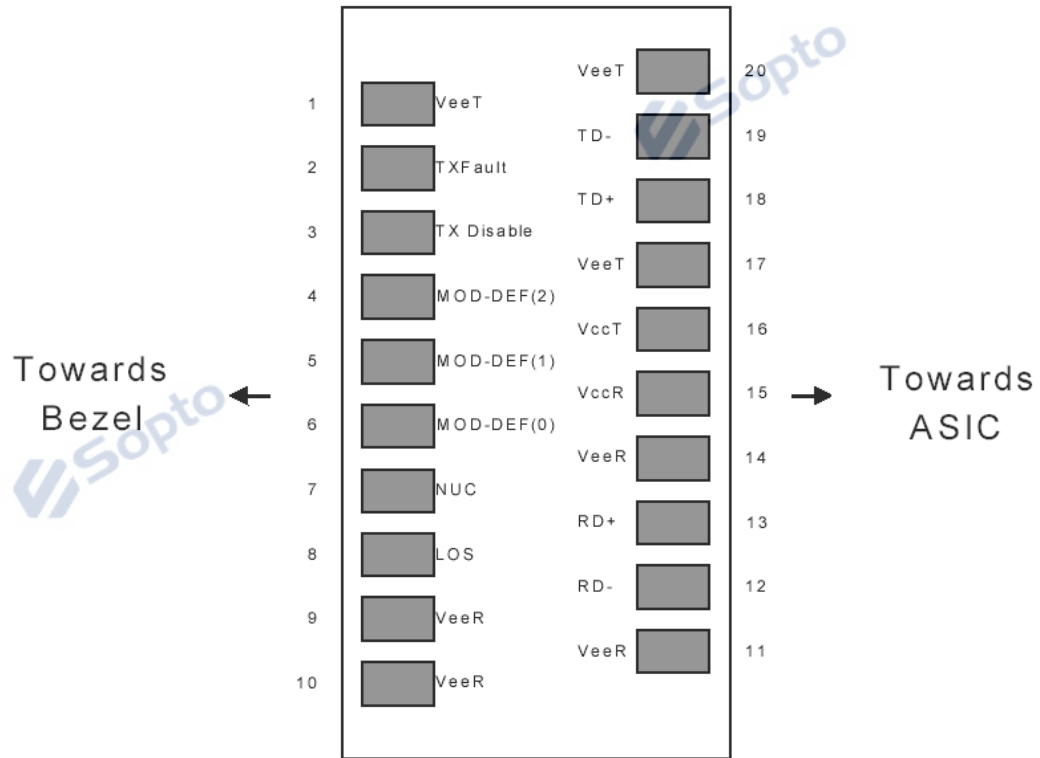

Diagram of Host Board Connector Block Pin Numbers and Names

Pin Function Definitions

Pin No	Name	Function	Plug Seq	Notes
1	VeeT	Transmitter Ground	1	1
2	TX Fault	Transmitter Fault Indication	3	
3	TX Disable	Transmitter Disable	3	2
4	MOD-DEF2	Module Definition	2	3
5	MOD-DEF1	Module Definition 1	3	3
6	MOD-DEF0	Module Definition 0	3	3
7	Rate Select	Not Connected	3	4
8	LOS	Loss of Signal	3	5
9	VeeR	Receiver Ground	1	1
10	VeeR	Receiver Ground	1	1
11	VeeR	Receiver Ground		1
12	RD-	Inv. Received Data Out	3	6
13	RD+	Received Data Out	3	6
14	VeeR	Receiver Ground	3	1
15	VccR	Receiver Power	2	1
16	VccT	Transmitter Power	2	
17	VeeT	Transmitter Ground	1	

18	TD+	Transmit Data In	3	6
19	TD-	Inv. Transmit In	3	6
20	VeeT	Transmitter Ground	1	

Notes:

1. Circuit ground is internally isolated from chassis ground.
2. Laser output disabled on TDIS >2.0V or open, enabled on TDIS <0.8V.
3. Should be pulled up with 4.7k - 10 kohms on host board to a voltage between 2.0V and 3.6V. MOD_DEF(0) pulls line low to indicate module is plugged in.
4. Rate select is not used
5. LOS is open collector output. Should be pulled up with 4.7k – 10 kohms on host board to a voltage between 2.0V and 3.6V. Logic 0 indicates normal operation; logic 1 indicates loss of signal.
6. AC Coupled

SFP Module EEPROM Information and Management

The SFP modules implement the 2-wire serial communication protocol as defined in the SFP -8472. The serial ID information of the SFP modules and Digital Diagnostic Monitor parameters can be accessed through the I²C interface at address A0h and A2h. The memory is mapped in Table 1. Detailed ID information (A0h) is listed in Table 2. And the DDM specification at address A2h. For more details of the memory map and byte definitions, please refer to the SFF-8472, “Digital Diagnostic Monitoring Interface for Optical Transceivers”. The DDM parameters have been internally calibrated.

Table 1. Digital Diagnostic Memory Map (Specific Data Field Descriptions)

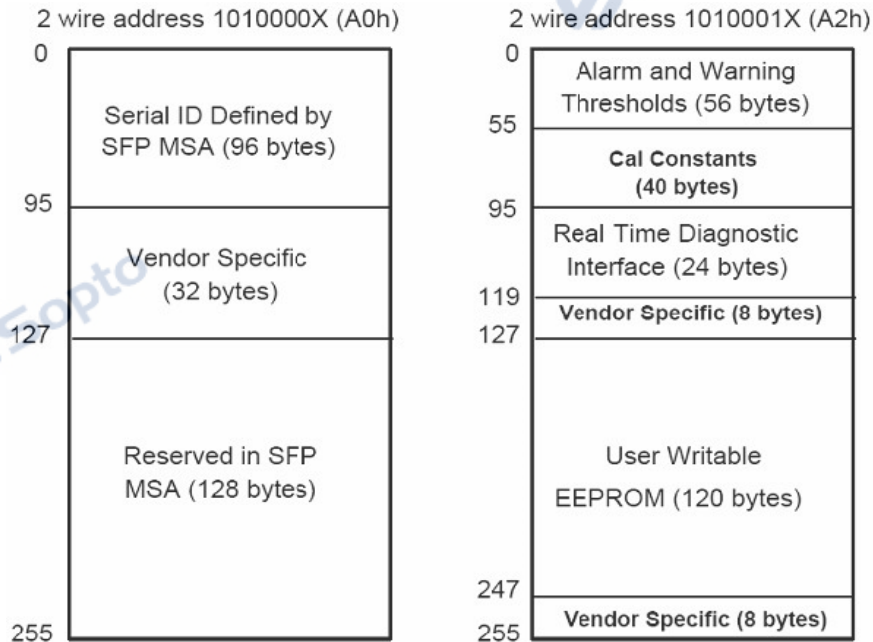

Table 2 - EEPROM Serial ID Memory Contents (A0h)

Data Address	Length (Byte)	Name of Length	Description and Contents
Base ID Fields			
0	1	Identifier	Type of Serial transceiver (03h=SFP)

1	1	Reserved	Extended identifier of type serial transceiver (04h)
2	1	Connector	Code of optical connector type (07=LC)
3-10	8	Transceiver	
11	1	Encoding	NRZ(03h)
12	1	BR, Nominal	Nominal baud rate, unit of 100Mbps
13-14	2	Reserved	(0000h)
15	1	Length(9um)	Link length supported for 9/125um fiber, units of 100m
16	1	Length(50um)	Link length supported for 50/125um fiber, units of 10m
17	1	Length(62.5um)	Link length supported for 62.5/125um fiber, units of 10m
18	1	Length(Copper)	Link length supported for copper, units of meters
19	1	Reserved	
20-35	16	Vendor Name	SFP vendor name: SOPTO
36	1	Reserved	
37-39	3	Vendor OUI	SFP transceiver vendor OUI ID
40-55	16	Vendor PN	Part Number: (ASCII)
56-59	4	Vendor rev	Revision level for part number
60-62	3	Reserved	
63	1	CCID	Least significant byte of sum of data in address 0-62
Extended ID Fields			
64-65	2	Option	Indicates which optical SFP signals are implemented (001Ah = LOS, TX_FAULT, TX_DISABLE all supported)
66	1	BR, max	Upper bit rate margin, units of %
67	1	BR, min	Lower bit rate margin, units of %
68-83	16	Vendor SN	Serial number (ASCII)
84-91	8	Date code	SOPTO's Manufacturing date code
92-94	3	Reserved	
95	1	CCEX	Check code for the extended ID Fields (addresses 64 to 94)
Vendor Specific ID Fields			
96-127	32	Readable	SOPTO specific data, read only
128-255	128	Reserved	Reserved for SFF-8079

Digital Diagnostic Monitor Characteristics(A2h)

Data Address	Parameter	Accuracy	Unit
96-97	Transceiver Internal Temperature	±3.0	°C
98-99	VCC3 Internal Supply Voltage	±3.0	%

100-101	Laser Bias Current	± 10	%
102-103	Tx Output Power	± 3.0	dB
104-105	Rx Input Power	± 3.0	dB

Regulatory Compliance

This SFP complies with international Electromagnetic Compatibility (EMC) and international safety requirements and standards (see details in Table following).

Electrostatic Discharge (ESD) to the Electrical Pins	MIL-STD-883E Method 3015.7	Class 1(>1000 V)
Electrostatic Discharge (ESD) to the Duplex LC Receptacle	IEC 61000-4-2 GR-1089-CORE	Compatible with standards
Electromagnetic Interference (EMI)	FCC Part 15 Class B EN55022 Class B (CISPR 22B) VCCI Class B	Compatible with standards
Laser Eye Safety	FDA 21CFR 1040.10 and 1040.11 EN60950, EN (IEC) 60825-1,2	Compatible with Class 1 laser product.

Recommended Circuit

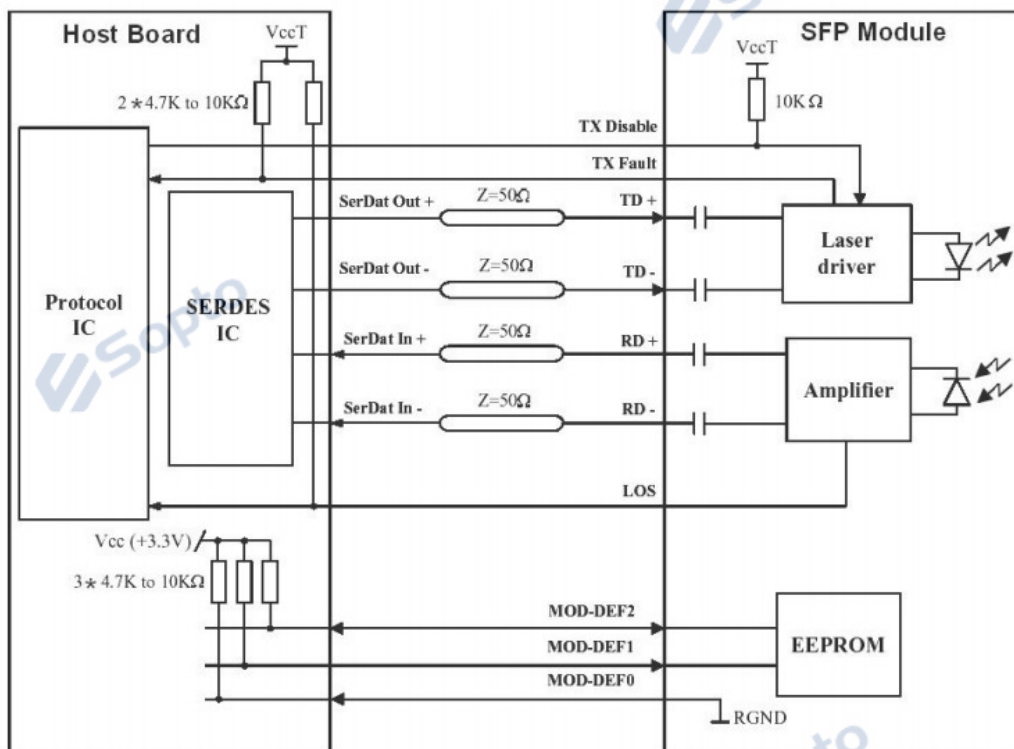

Mechanical Dimensions

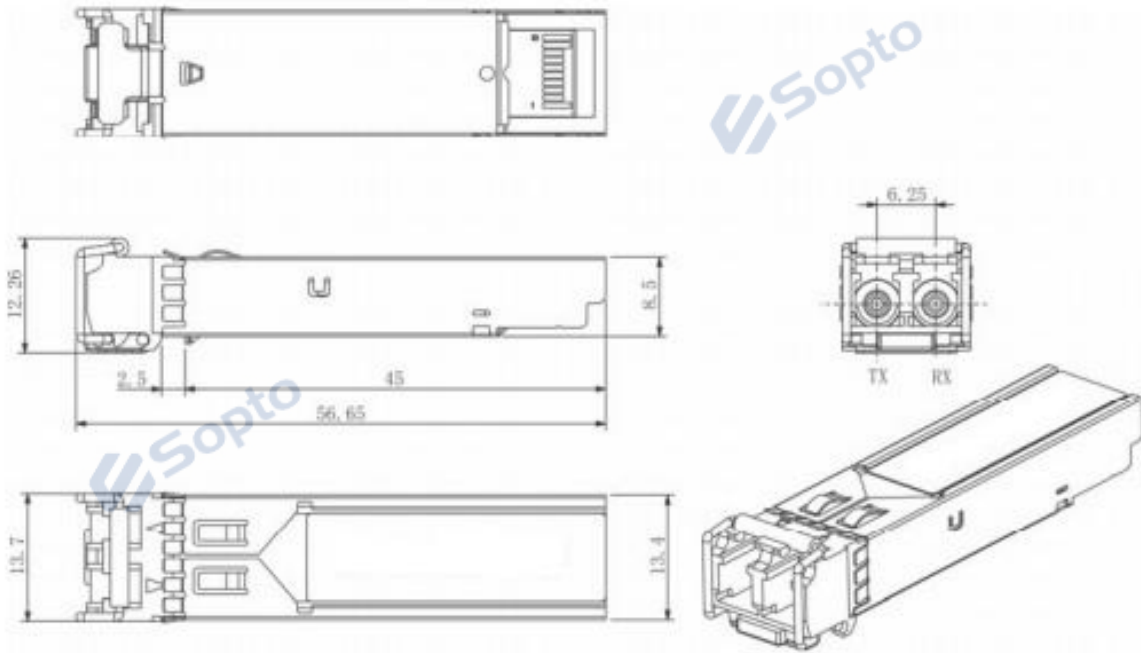

Unit:mm

Ordering information

Part Number	Product Description
SPT-P1348-10	1310nm, 2.5Gbps, 10km, 0°C ~ +70°C
SPT-P1348-10D	1310nm, 2.5Gbps, 10km, 0°C ~ +70°C, DDM
SPT-P1348-10TD	1310nm, 2.5Gbps, 10km, -40°C ~ +85°C, DDM

E-mail: info@sopto.com.cn

Web : <http://www.sopto.com.cn>